

# M Mountain State Sierran

VOLUME 50, NUMBER 1

SPRING 2024

## New Federal Protection for Old Growth Trees



BY **BETSY  
JAEGER LAWSON**

As reported in last summer's Mountain State Sierran, old growth and mature trees in the Monongahela National Forest are under threat because of a U.S. Forest Service plan to clear-cut 3,463 acres of mature hardwood trees along the Upper Cheat River. The National Sierra Club calls the plan one of the 12 worst logging projects in the country, and Sierra Club members, along with Friends of Blackwater, held two rallies in Elkins and Morgantown to protest the project.

On Earth Day 2022, President Biden issued an executive order to conserve and restore old and mature forests, but nothing had been done about it until now. In a December 19, 2023 press release, the Forest Service announced "a proposal to amend all 128 forest land management plans to conserve and steward old-growth forest conditions on national forests and grasslands nationwide." This is the first time ever that the Forest Service has said its national policy will be to protect old growth forests rather than give free reign to the timber industry. What changed?

Last year, the U.S. Forest Service held a public comment period asking for feedback on management of mature and old-growth forests on federal land. More than 500,000 people submitted comments, many of which were delivered by the Sierra Club. In addition



The blue outline indicates R45, a proposed cut for the Upper Cheat Logging Project.  
PHOTO: FRANK GEBHARD, FRIENDS OF BLACKWATER.

to these comments of half a million people, extensive wildfires, disease, pests, and forests degraded by decades of aggressive logging and climate change apparently caused Agriculture Secretary Tom Vilsack to do something. (Yes, public comments do make a difference.)

A Notice of Intent to prepare an Environmental Impact Statement will apply to 25 million acres of old growth and more than 68 million acres of mature trees in national forests and grasslands. However, while logging will be sharply limited in old growth forests, it

[CONTINUED ON PAGE 3](#)

### Inside this Issue

2 | From the Chair

2 | Chapter Directory

3 | Pyrolysis Facility in Follansbee

4 | From the Director

5 | Legislative Season for WVEC

6 | New Solar Opportunities

7 | Chemours & PFAS in the Ohio Valley

7 | Growing Up in Coal Country

8 | New Protections for Salamanders

9 | Wilderness Act Turns 60

10 | Outings

14 | Environmental Justice

15 | Membership Survey

[SIERRACLUB.ORG/WEST-VIRGINIA](https://sierraclub.org/west-virginia)

# Sierra Club's New Conservation Program



BY JIM KOTCON

**The Sierra Club's ongoing reorganization includes the consolidation of National Conservation Campaigns. Rather than using a plethora of names to describe similar programs, the Club is organizing its initiatives around four issue areas, although key themes often overlap. No matter what your interests include, the WV Chapter can use your help in furthering environmental initiatives. Better still, we can connect you with resources to make your actions more effective.**

**The Fossil Fuels Campaign** now includes Beyond Coal, Beyond Dirty Fuels, and the Fossil-Free Finance Campaigns. The goal of these programs is to address climate change by shifting from fossil to renewable energy as quickly as practicable. This campaign dominates our work here in West Virginia, due to the state's longstanding reliance on coal and fossil gas, as well as to ongoing efforts by political leaders to extend the life of these climate contributors. (You may have noticed how seldom the word "climate" is used when WV leaders discuss fossil fuels; they seem truly afraid to even say it out loud!)

**The Clean Transportation Campaign** focuses on rapid electrification of the transportation sector. Transportation is now the largest contributor of greenhouse gases in the U.S., and its negative impact continues to grow. In West Virginia, electric school buses are a cost-effective way to reduce emissions, protect children's health, and, with federal grants widely available, save significant money for local taxpayers. Some electric school buses are now being made here in West Virginia, so talk to your local school board to find out what you can do to advocate for the adoption of electric school vehicles.

**The Lands and Wildlife programs** help protect our local, state, and national treasures. These programs include the Club's 30-by-30 Campaign (whose goal is to protect 30% of the planet's land and water by 2030), as well as Climate, Forests, Wilderness, and more. Protecting wild land and mature forests may result in greater carbon sequestration while also protecting wildlife and water. New efforts include policies to encourage rapid conversion to renewables while protecting wild habitats.

Finally, the **Water Program** works to protect clean water, restrict toxic chemicals, and strengthen climate resilience.

The Club is working on all these efforts through national legislative and federal agency campaigns, the Environmental Law Program, and state and local volunteers. Many members start out just looking for a group to enjoy the outdoors (as I did), but then grow to help protect those outdoor areas, and the planet as a whole.

**The antidote for apathy is action!** If you are ready to do more, contact us. You can reach me at [jkotcon@gmail.com](mailto:jkotcon@gmail.com) or 304-594-3322.

## West Virginia Sierra Club Chapter Directory

Email contact for all officers and staff: [sierraclub.wv@gmail.com](mailto:sierraclub.wv@gmail.com)

*Term ends at first meeting of indicated year.*

### CHAPTER EXECUTIVE COMMITTEE

<b>Jim Kotcon, Chair</b>	( '26)	304-594-3322
<b>Kevin Campbell, CCL Delegate</b>	( '25)	304-613-4099
<b>Davis Funk</b>	( '25)	
<b>Dani Parent</b>	( '26)	
<b>Bill Price</b>	( '26)	
<b>Chrissy Sandy, Secretary</b>	( '25)	
<b>David Sturm</b>	( '25)	304-612-0024
<b>Candice Elliott, Treasurer</b>		

### MONONGAHELA GROUP EXCOMM

<b>Michael Attfield, Vice Chair, Chpt Delegate</b>	( '24)	
<b>Jim Kotcon</b>		
<b>James Lamp</b>	( '25)	
<b>Betsy Lawson, Secretary, Membership</b>	( '24)	304-983-2980
<b>Sally Wilts, Treasurer</b>		304-379-7567

### EASTERN PANHANDLE GROUP EXCOMM

**Currently Inactive.**  
For information, contact Chris Craig at [ccraig@laurelodge.com](mailto:ccraig@laurelodge.com).

### OTHER CHAPTER LEADERS

<b>Kathy Gregg, Archives/Chapter History</b>	
<b>Bill Price, Conservation</b>	
<b>Chris Craig, Newsletter &amp; Outings</b>	304-433-1260
<b>David Sturm, Political</b>	304-612-0024
<b>Mel Waggy, Public Lands &amp; Membership</b>	304-497-4358
<b>Davis Funk, Webmaster</b>	
<b>Karen Yarnell, Wilderness</b>	

### REGIONAL SIERRA CLUB ORGANIZING STAFF

<b>Honey May, WV Chapter Director</b>	304-356-8774
<b>Alex Cole, Senior Organizer,</b>	304-767-8687
<b>Beyond Coal/Beyond Dirty Fuels</b>	

# Follansbee Pyrolysis Facility Pivots Plans to Process Plastics



BY NATALIE ROCCHIO

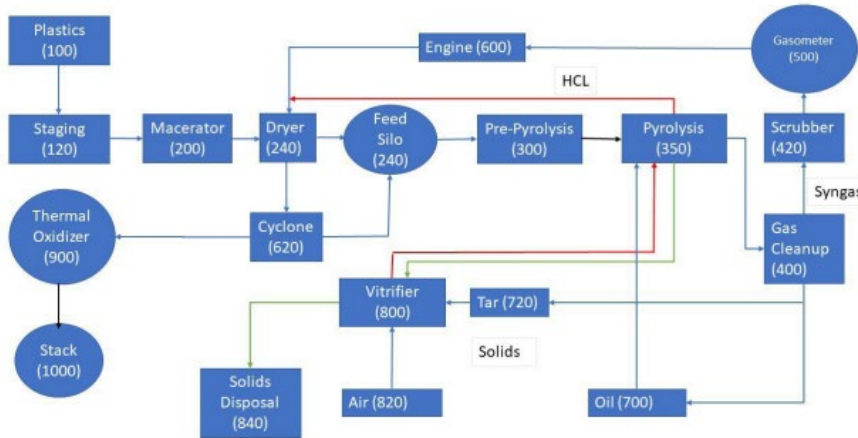

Figure 1. Block flow diagram for detailed process description

## Original Plans for the Facility

In 2022 residents of Follansbee, WV strongly opposed the operation of a medical waste pyrolysis facility planned by Empire Green Generations LLC. After a public hearing for the consideration of an air permit from the West Virginia Department of Environmental Protection, Division of Air Quality (DAQ), the permit was issued on March 2, 2023. The next step in the process would have been to seek a permit through West Virginia's Department of Health and Human Resources to process infectious waste. However, shortly after the DAQ permit was issued, Empire stated they would no longer seek to process medical waste at the facility.

## New Plans for the Facility

Representatives from Empire Green Generations attended a December City Council meeting to present a new building permit application for a new bladder building to process plastics at the pyrolysis facility. The company also submitted a permit modification to DAQ that same week. The modification

application states that the facility will not process medical waste, but rather plastics with resins 1-7. The City Council delayed voting on the permit until more information could be provided.

Empire Green Generations hosted a community meeting, which was well attended. However, no recording devices were allowed in the meeting. Empire stated they could effectively process all plastic resins because of a pre-pyrolyzing step that is not currently in use anywhere in the United States. The company highlighted that the pyrolysis facility would be used to power a pig iron facility proposed for the same area. They said they plan to hold community engagement events once a quarter and establish a community advisory board.

Following the meeting, the City Council held a special meeting to vote on the building permit. The permit was approved 5-1 (see <https://wtov9.com/news/local/follansbee-officials-approve-permit-for-bladder-building-for-proposed-pastic-recycling-plant>).

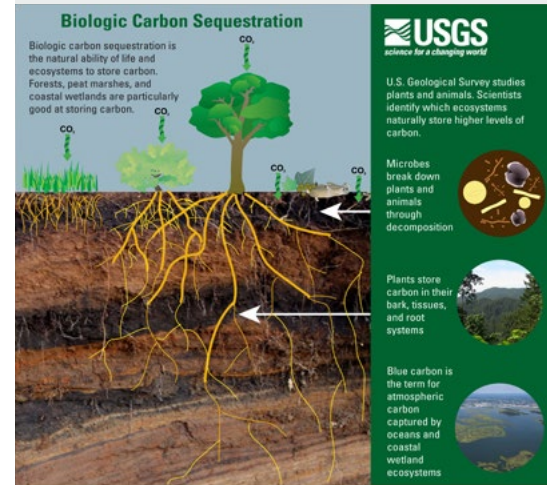

U.S. Geological Survey. PUBLIC DOMAIN

## OLD GROWTH | CONT. FROM PAGE 1

may still be allowed in mature forests. The proposal to revise management plans for 128 national forests and national grasslands is expected to be completed by early 2025. However, it's uncertain if the change would survive if President Biden loses his 2024 re-election bid.

How will these recent actions affect the Upper Cheat River logging project? On January 24, WVSC Chair Jim Kotcon and Judy Rodd of Friends of Blackwater submitted a letter to the Deputy Chief of the National Forest System, emphasizing that the Upper Cheat River project should be rejected since it would directly contradict the intent of the new executive order. Let's hope that by the next newsletter, we'll have a response and a positive decision to scrap the Upper Cheat River project forever.

We attempted to follow up with Empire Green Generations for a list of other pyrolysis facilities outside of the United States operating a pre-pyrolyzer. However, Empire stated that Technotherm, manufacturing company of the pyrolysis equipment, declined to share that information.

## Next Steps

As of the end of January 2024, DAQ was still awaiting final documentation to be completed by Empire to consider their permit modification. DAQ will publicize a public comment period for the permit in the coming months. 🌱

FROM THE DIRECTOR

# Sunny Days Are Near Again



**BY HONEY MAY**

**As the Chapter Director of the West Virginia Chapter of the Sierra Club, I'm witnessing a pivotal moment in our state's legislative session that could significantly shape our energy future. Amidst a flurry of legislative activity, two pieces of solar legislation stand out, which together have the potential to usher in a new era of renewable energy access and empowerment for West Virginians. It's a time of hope and action for all of us committed to a sustainable future.**

## NET METERING

Net metering is a billing mechanism that credits solar energy system owners for the electricity they add to the grid. A critical piece of legislation (HB 5422) is on the table, aimed at preserving and codifying the rights of solar energy producers to fair compensation. This bill isn't just about promoting renewable energy; it's about defending the financial and ethical fairness for individuals who've taken a step towards a cleaner, sustainable future.

## THE CURRENT STATE OF NET METERING

In West Virginia, the existing net metering practice offers a beacon of hope for those of us committed to reducing our reliance on fossil fuels. Currently, individuals who generate their own electricity through solar panels are credited at a retail rate for any excess power they contribute back to the grid. This arrangement not only makes solar energy more financially viable for homeowners and businesses but also incentivizes the shift towards green energy solutions.

## THE THREAT FROM UTILITIES

However, this progressive practice is under threat. MonPower and Potomac Edison are pushing to cut the compensation rate in their current proceedings on utility rates, aiming to reduce the amount paid to solar generators for their excess power. Such a move would not only undermine the economic benefits of installing solar panels but also slow down West Virginia's transition to renewable energy sources. The implications of this push by utilities are far-reaching, and could dissuade potential adopters of solar.

## THE NET METERING BILL: A STAND FOR SOLAR FAIRNESS

The net metering bill currently under consideration is a critical countermeasure to protect the interests of solar energy producers. By

codifying the retail rate compensation for excess power, the bill aims to safeguard the rights of individuals to fair and just compensation for the energy they contribute back to the grid. This legislation is not just about maintaining the status quo—it's a stand for the principle of fairness and encourages the continued growth of solar energy in West Virginia.

The bill represents a clear message to utilities and policymakers alike: The transition to renewable energy is not just an environmental imperative but also a matter of economic fairness and justice for West Virginians. By securing the retail rate for net metering, we ensure that investing in solar remains attractive and viable for our citizens. Supporting this legislation reinforces our commitment to a sustainable energy future.

## A COMMUNITY SOLAR BILL: A COLLECTIVE LEAP FORWARD

Equally transformative is the proposed community solar bill (SB 638), a promising avenue for equitable access to renewable energy. This legislation enables the creation of community solar projects, in which individuals can buy into a shared solar energy system, even if they cannot install solar panels on their own properties. It's a game-changer for renters, apartment dwellers, and those without the financial means to go solar independently.

---

**“It's a time of  
hope and action  
for all of us  
committed to a  
sustainable future.”**

---



PHOTO BY CHRIS JACKSON.

# WVEC Busy in New Legislative Season

The West Virginia Environmental Council (WVEC) has been monitoring legislative activities throughout 2023, and our lobby team is now at the legislature advocating for our environmental and health priorities.



**BY JILLIAN WELSH**

The session began on Wednesday, January 10, 2024. Key bills we're monitoring include protecting net metering, advancing community solar, protecting our public lands, addressing abandoned and orphaned gas wells, and assuring that community air monitoring remains in use in West Virginia. Be sure to check out the latest news in our GREEN newsletter at [wvecouncil.org](http://wvecouncil.org) and subscribe to receive Legislative Updates and Action Alerts here (which continue throughout the year).

We are excited to introduce you to this year's lobby team, which includes returning team member Lucia Valentine and new lobby team member Isabel Stellato. I, Jillian Welsh, will continue as the communications coordinator.

We're happy to announce WVEC's new board members and officers. Sandra Fallon is our new President, and Linda Frame now serves as the immediate Past President. Sandra has been WVEC's Vice-President since 2022. She looks forward to building on Linda's impressive accomplishments by continuing to improve our internal operations, expanding our lobbying efforts, building stronger coalition partnerships, and engaging more citizens and students in the legislative process.

We all appreciate Linda's commitment and the expertise she brought to WVEC. We are grateful that she's continuing to work with us as Past President and our Legislative Chair, managing our lobbying efforts and lobby team.

The WVEC Board is pleased to welcome two new members, Quenton King and Francie Price. Quenton was elected WVEC Vice-President in November, bringing a wealth of environmental and policy experience. He currently serves as a Federal Legislative Specialist at Appalachian Voices, chairs the Charleston Green Team, and has worked with the WV Center for Budget and Policy and the WV ACLU. Francie is a WVU graduate and an artist passionate about the environment. She paints landscapes that portray

our changing climate and is committed to working to protect our planet and future generations.

WVEC is proud to work in partnership with the Sierra Club as a long-term member and contributor. Be sure to look for the latest legislative news on our website, [wvecouncil.org](http://wvecouncil.org).

Community solar represents the democratization of energy production. It ensures that the benefits of solar power—reduced electricity bills, decreased reliance on fossil fuels, and a smaller carbon footprint—are accessible to all, not just a privileged few. By investing in community solar, West Virginians can collectively contribute to and benefit from the transition to renewable energy, fostering a sense of community and shared purpose in the fight against climate change.

## A POWERFUL SHOW OF SUPPORT

In a stirring demonstration of solidarity and support for solar energy, over 130 individuals, many of whom are Sierra Club members, rallied at the Capitol for a "Save Our Solar" rally in January. This powerful gathering was a testament to the collective will of the people of West Virginia to advocate for sustainable energy policies and to show unwavering support for the net metering and community solar bills. The rally underscored the importance of these bills to our community and sent a clear message to legislators about the public's demand for a renewable energy future.

**The Legislative Session ends March 9, 2024, and at the time of this publication the prospect of these bills passing remains uncertain. To find their status and take action or to find how your representatives voted, contact me, Honey May, at [honey.may@sierraclub.org](mailto:honey.may@sierraclub.org) or 304-356-8774. With warm regards and shared resolve, Honey May**

Chapter Director  
West Virginia Chapter of the Sierra Club



WVEC Lobbyists Isabel Stellato (L) and Lucia Valentine at the State Capitol in Charleston. PHOTO BY JILLIAN WELSH.

# “I Love ~~Coal~~ Solar” in West Virginia?

BY BETSY JAEGER LAWSON

**West Virginia ranks 49th in the nation for too many quality-of-life standards, and solar energy installation is one of them. But slowly, kicking and screaming, our coal-dominated state is coming around to renewable energy. In 2020, the WV legislature, convinced by Delegate Evan Hansen (D-Morgantown) that access to renewable energy encourages economic development, passed SB 583, which allows WV utilities to own and operate up to 200 megawatts of solar energy. (One MW of solar energy can power 173 households.)**



*Partial view of Fort Martin Solar Facility, as seen from entrance to Longview coal-fired power plant with steam from Fort Martin coal-fired plant in background. PHOTO: BETSY LAWSON*

With this legislative green light, Mon Power and Potomac Edison, subsidiaries of First Energy, started plans for five solar facilities. The Public Service Commission granted approval for construction when enough industrial, commercial, and residential customers subscribed to use 85% of the renewable energy generated at the sites. First in line, the town of Harpers Ferry subscribed for enough solar energy to supply 100% of its streetlight and town hall energy usage.

So far, three of the five solar sites planned have met the PSC 85% subscription rate. Mon Power is encouraging its customers to buy the solar credits needed to develop the other two sites. But subscriptions won't be the only source of funding for the three approved solar projects. The PSC allowed First Energy's request for a construction surcharge on all its customers. So, the average residential customer using 1,000 kilowatt hours per month will start paying an extra 14 cents per month, dropping to 11 cents per month in 2026. In the future, they hope that only solar customers will pay all the costs for existing and new solar projects.

The first of the five solar facilities went online this past January 4th next to the **Fort Martin** coal-fired power plant north of Morgantown. It covers 80 acres with 49,032 solar panels generating 18.9 megawatts for the PJM grid, or electricity for up to 3,287 homes in the area. First Energy is quick to point out that the site was constructed with 100 local union workers from Morgantown and Parkersburg and that the panels, racks, and electrical equipment were all made in the U.S. The panels are designed to withstand hail up to a certain size and are slick enough that snow slides right off.

The second and third sites to get the PSC go-ahead are a 27-acre retired ash disposal site in **Rivesville**, north of Fairmont, and a 26-acre reclaimed ash disposal site in **Marlowe** in Berkeley County, with completion expected by the end of this year. Mon Power is waiting for enough subscribers before asking the PSC for permission to develop the two remaining sites. With completion planned for the end of 2025, these projects would be on a 44-acre reclaimed strip mine in **Davis**

and on a 51-acre site next to a Mon Power substation in **Weirton**. Altogether, these five solar facilities will bring 50 MW of solar to the table – and that's part of a 517 MW growth projection over the next five years, which will bump West Virginia up to 45th in the nation for utility-scale solar production.

First Energy customers in WV who want access to solar energy without going off the grid now have two options: install one's own panels or subscribe to the Mon Power plan. A future third option would be Community Solar. This plan allows any building owner with a big, sun-exposed roof, such as malls, churches, hospitals, factories, parking garages—or a free-standing purpose-built structure—to install solar panels and then sell their excess energy to subscribers. This energy would have to pass through the grid's existing infrastructure but would open up great possibilities for solar expansion in WV. But so far, it can't happen here because of existing laws. In the 2023 legislative session, Delegate Hansen introduced HB 2159, which would authorize Community Solar and require the PSC to regulate it. Thanks to the coal lobby, it was defeated. Passing this bill is a legislative priority for the WV Environmental Council, to which our Sierra Club chapter belongs.

It was suggested that the reason that Mon Power wants to reduce 1:1 net metering on domestic solar producers is to force customers desiring solar energy to subscribe to Mon Power's solar sites. The PSC should deny this request. We need more, not fewer, energy options.

**Meanwhile, if you want access to solar energy without installing panels, your only option is to subscribe at [firstenergycorp.com/WVSolar](https://www.firstenergycorp.com/WVSolar) or by calling 1-800-505-7283. Subscription levels range from \$2 per month for 50 kwh to \$40 per month for 1,000 kwh. Sunshine is free, but Mountaineers are not free when it comes to energy options.**

# Chemours Applies to Continue Causing “Dark Waters”



BY ERIC ENGLE

**Those of us living in the Mid-Ohio River Valley are tired of being the victims of water pollution. We live on what has consistently been the most- or second-most-polluted river in the country, the mighty Ohio. A drinking water source for five million people and a river steeped in history, the Ohio has for decades been treated like a toxic waste dump by industry more concerned about profits than people.**

A recent proposal by Chemours (formerly DuPont) for a permit to install a new PFAS production line at its Washington Works site in Washington, WV is the latest instance of a long history of disregard for the beauty, biodiversity, and health of the Ohio River. PFAS (Per- and Polyfluoroalkyl Substances) are a class of about 12,000 chemicals known as “forever chemicals,” because they don’t degrade or break down in the human body. Instead, they bioaccumulate. They’re used to make what are called fluoropolymer coatings and products that resist heat, oil, stains, grease, and water.

A type of PFAS known as PFOA (Perfluorooctanoic Acid) contaminated our water in this area from the Washington Works

facility for decades. The PFOA known as C8 (carboxylic acid) contaminating our water was definitively linked in an almost 70,000-person health study to high cholesterol, ulcerative colitis, thyroid disease, testicular cancer, kidney cancer, and pregnancy-induced hypertension. Now Chemours wants a permit from the WV Department of Environmental Protection (WVDEP) for another production line of this highly dangerous chemical class.

Both the documentary film “The Devil We Know,” which appeared on Netflix, and the major motion picture “Dark Waters” covered the legal fight against C8 contamination by DuPont. Still, not much has changed in the area. The EPA issued federal exposure guidelines on PFAS in 2023, stating that exposure to PFOA

should be limited to 0.004 parts per trillion (ppt) and exposure to another PFAS known as PFOS (Perfluorooctane Sulfonic Acid) 0.02 ppt. This is as close to zero exposure as the EPA could get in an economy where PFAS are part of countless products.

These substances must stop being produced and must be removed from our world permanently. That’s why Mid-Ohio Valley Climate Action partnered with the West Virginia Rivers Coalition to try to fight this permit Chemours is requesting. **Due to our lobbying, the deadline for public comment on permit application WV0117986 has been extended by WVDEP to 5 p.m., Thursday, March 14, 2024.**

[CONTINUED ON PAGE 11](#)

# Friend of Coal – NOT

**When you live in West Virginia, many folks expect you to be a “Friend of Coal,” to support the miners, and be proud that we “kept the lights on” for decades. Coal is a way of life in the Mountain State, from the history of mining to fights for fair wages and safe working conditions. But our past doesn’t have to determine our future.**

Growing up in West Virginia, we burned coal. I remember the pungent smell of coal smoke billowing out of the chimney like it was yesterday. I also remember watching the ash fall to the ground, leaving the snow with black speckles, freezing the snow where the ash landed hot, then freezing again. Every snowman I built had coal ash specks riddled throughout his body. I ate that snow. I played in that snow. It melted and filled up our well.

I also carried buckets of coal into the house to feed the wood and coal stove we used to heat our house. I carried buckets of ash out of the house, dumping them over the hill. These were part of my chores. Coal kept us warm in the winter, and it was cheaper than alternative fuels.

My grandfather was a coal miner, and I have other family members who were part of the coal industry. My family’s



BY CHRISSY SANDY

farmland is part of a strip mine. It was stripped in the 1960s, and the land was then used to raise cattle and hay. Coal is in my blood. As an adult, I look back and wonder how many other families in the neighborhood burned coal. I think about the fact that I breathed

[CONTINUED ON PAGE 12](#)

# Rare Salamanders Considered for Endangered Species Act Protections

**On January 17, the Center for Biological Diversity filed a formal notice of its intent to sue the U.S. Fish & Wildlife Service (USFWS) for failing to make a decision on whether *Plethodon pauleyi*, the yellow-spotted woodland salamander, warrants protection under the Endangered Species Act. They did the same for *Aneides caryaensis*, the hickory nut gorge green salamander, on January 18. These actions were taken after the USFWS failed to make an initial decision on these matters within the required 90-day period following the submission of a petition to list the species. In response to the lawsuits, the USFWS announced they will be considering both species for protections under the ESA on January 24.**

**BY FRANK GEBHARD**

The yellow-spotted woodland salamander is found in Tennessee, Kentucky, and West Virginia, and was recently discovered to also occur in Virginia. They are habitat specialists, solely residing on and within shale and sandstone outcrops. They have flat, slender bodies and wide feet that assist them in traversing their rocky, crumbly habitats. Fewer than 400 of them remain, and they are under threat of habitat loss due to road building and coal mining.

The species was named in honor of Dr. Thomas K. Pauley, a Professor Emeritus from Marshall University, for his studies on *Plethodon wehrlei*, the Wehrle's salamander. This previously wider-ranging species was recently re-evaluated and split into multiple species (including *P. pauleyi*) in 2019 by Felix et al\*.

*Aneides caryaensis*, the hickory nut gorge green salamander, can only be found within the Hickory Nut Gorge in North Carolina, a 14-mile gorge seated in the Blue Ridge Mountains. They too are rock outcrop specialists, occupying small crevices within sandstone outcrops. They are similar to the West Virginia native species *Aneides aeneus*, the green salamander. The hickory nut gorge green salamander is different from the green salamander in that their bodies are covered in a lower amount of green patterning, their feet are wider, their toes are longer, and their heads are larger. The green patterning they exhibit is also a bit brighter and more yellow-green compared to the green salamander. Their remaining population is estimated at just 250 individuals, and they are at risk of habitat loss due to human development, rock climbing, and other recreational activities within their habitat.

Luckily, the USFWS proposed to protect *Gyrinophilus subterraneus*, the West Virginia spring salamander, on December 19, 2023. This species inhabits a singular cave system in Greenbrier County, WV. It is a troglomorphic (cave-dwelling) species of salamander that is unique in its tendency to undergo a complete metamorphosis to an adult salamander. Most troglomorphic salamanders are paedomorphic, meaning they retain juvenile characteristics as adults and never lose their gills for life on land. Fewer than 300 of them remain, and it is great news that they are receiving the protections they need.

We hope that all three species end up being placed on the Endangered Species List as they so obviously deserve. Thank you to the USFWS for proposing actions to protect these imperiled species. 🍄

\*Felix, Z.I., Wooten, J.A., Pierson, T.W. & Camp, C.D. (2019) Re-evaluation of the Wehrle's salamander. <https://doi.org/10.11646/zootaxa.4609.3.2>



All photos by Frank Gebhard, shown photographing the wild wonders of WV



*Plethodon Wehrlei*

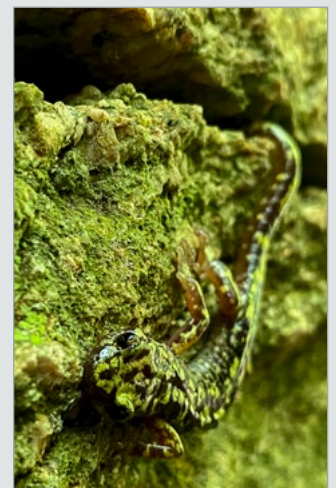

*Aneides Caryaensis*

**For more information on salamander species protection,** see <http://biologicaldiversity.org/w/news/press-releases>.

**On salamander species,** see <https://amphibiaweb.org>.



# JOIN THE CLUB!

With vital landmark legislation like the Endangered Species Act under attack, and the regulatory powers of the EPA threatened in Congress, we need you to join us as a member to beat back rollbacks on the progress we've made protecting our national heritage. In addition to our ambitious work across the country, part of your membership dues support the West Virginia Chapter.

Add your voice to the hundreds of thousands of Americans committed to leaving our children a living legacy — clean air, safe drinking water, and natural grandeur. From Yosemite National Park to the Grand Canyon, since 1892 the Sierra Club has been instrumental in preserving nature's most splendid wild places.

**Please join us in this movement by becoming a Member today!** Join online at [Join Today](#). Become a champion. [sierraclub.org](#)



*Plethodon pauleyi*

## The 60th Wilderness Anniversary Celebrate the Wild!

**BY VICKY HOOVER**

The year 2024 has arrived, and with it the sixtieth anniversary of the Wilderness Act that established America's National Wilderness Preservation System. It is time to begin celebrating 60 years of wilderness preservation: wilderness by law.

On September 3, 1964, when President Lyndon Johnson signed the Wilderness Act, he brought into being a brand-new national wilderness system protecting 54 areas in 13 states—places that had already been administratively protected by the Forest Service. But because such administrative protection was temporary and haphazard, wildlands advocates saw that a national law was needed for enduring protection of wild, natural land from development.

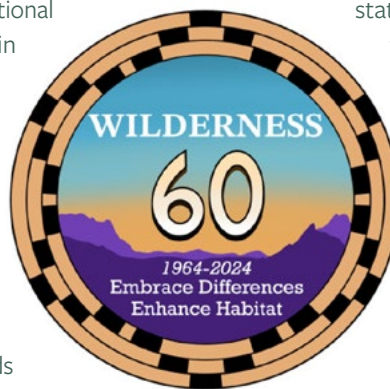

Today, that wilderness system has grown to 806 areas in 44 states plus Puerto Rico, with stewardship by all four federal land agencies. Plenty of reason to celebrate—and to work for even more lands to receive such protection.

New awareness that preserving nature can combat the climate crisis and fight the world's species extinction crisis gives us even more reason to fight to protect large swaths of natural land—in our national 30 by 30 Campaign. Let's start by celebrating what we have achieved! To join the Sierra Club's nationwide effort in YOUR chapter, contact Vicky Hoover, Wildlands Team Sixtieth co-coordinator, at [vicky.hoover@sierraclub.org](mailto:vicky.hoover@sierraclub.org).

**“[W]ilderness is an anchor to windward. Knowing it is there, we can also know that we are still a rich nation, tending our resources as we should, not a people in despair searching every last nook and cranny of our land for a board of lumber, a barrel of oil, a blade of grass, or a tank of water.”**

—SENATOR CLINTON ANDERSON OF NEW MEXICO

### Discover Otter Creek!

West Virginia chapter members will have the opportunity to discover one of the Mountain State's wilderness areas on a June 15 hike. See the outings listings for details.

# Outings

A Veterans Day hike brought out 19 Sierrans to explore trails through forests and fields and along the Shenandoah River at Shannondale Springs Wildlife Management Area, Jefferson County. Here with the Blue Ridge in the background. PHOTO BY ED WHEELLESS



## Saturday, February 17, 2024

### DAY HIKE: Swallow Falls State Park, Oakland, MD

This hike is open to all. Just a bit over a mile long, it goes through an old growth forest and passes by several waterfalls, including Muddy Creek Falls, the highest free-falling waterfall in Maryland. The route is moderate in difficulty, and due to the winter conditions, trails will likely be snow- and ice-covered. However, it is a beautiful hike. We are doing the hike on the same day as Oakland, Maryland's Winterfest, which offers more things to do in the area after a long drive for most hike participants.

- Distance/** 1.5 miles
- Difficulty:** EASY (But with icy trails likely)
- Duration:** 1.5 hours plus time for Winterfest
- Bring:** Water, snacks, and footwear and clothing appropriate for the conditions
- Meet:** Swallow Falls State Park parking lot, 2470 Maple Glade Road, Oakland, MD
- Leader:** Ken Kendall  
kekendall65@gmail.com  
304-433-9537
- Nearest town:** Oakland, MD
- Cancellation policy:** Due to the long drive in winter, stay in touch with the trip leader for potential cancellations.

## Saturday, February 24, 2024

### DAY HIKE: Maryland Heights, Harpers Ferry National Historical Park

In warmer seasons, this trail is overrun with crowds. Yet in the quieter winter months, Maryland Heights offers even better views of the surrounding landscape, and its fortifications and cannonades are clear of summer vegetation. The hike is open to all adults and children (with adult supervision) in shape for a multi-hour hike on steep and sometimes-rugged trails. It includes a 1400-foot climb. Along with the Heights' iconic view of Harpers Ferry, the hike will feature some historic and environmental background of the area.

- Distance/** 6.5 mile
- Difficulty:** MODERATELY DIFFICULT
- Duration:** 4 hours
- Bring:** Plenty of water and a sack lunch. Hiking poles or a walking stick may be helpful. Dress in layers for a winter hike's potential for varying temperatures and conditions.
- Meet:** 10 a.m. Old Shipley School parking lot, 850 Fillmore Street, Harpers Ferry. (Across from Appalachian Trail Conservancy headquarters, this is *not* Shipley Elementary off US 340.)
- Leader:** Chris Craig  
ccraig@laurelodge.com  
304-433-1260
- Nearest town:** Harpers Ferry, WV
- Cancellation policy:** We will carry on in light rain or snow but cancel in heavy precipitation or icy conditions.

## Saturday, March 9, 2024

### DAY HIKE: Tuscarora and Pee Wee Point Trails, Berkeley County, WV

Continuing our exploration of the Tuscarora Trail in West Virginia, we will hike out-and-back along a forest ridge in Sleepy Creek Wildlife Management Area, with a detour to a scenic overlook at Pee Wee Point. It is suitable for adults and children (with adult supervision) in reasonable shape and able to handle hills and uneven terrain. There is no charge for the hike, but contributions are welcome.

- Distance/** 7 miles
- Difficulty:** MODERATELY DIFFICULT
- Duration:** 4 hours
- Bring:** Plenty of water and a sack lunch. Hiking poles or a walking stick may be helpful. Dress in layers for an early spring hike's potential for varying temperatures and conditions.
- Meet:** 10 a.m. Hampshire Grade Road at the Tuscarora Trail. From WV 7 4.5 miles north of Glengary, turn up the hill on Hampshire Grade Road (CR 7/13) and go 4.5 miles to the top. There is parking along the shoulder near the trail intersection.
- Leader:** Chris Craig  
ccraig@laurelodge.com  
304-433-1260
- Nearest town:** Glengary, WV
- Cancellation policy:** We will carry on in light rain or snow but cancel in heavy precipitation or icy conditions.

## Saturday, March 16, 2024

### DAY HIKE: C&O Canal Towpath, Paw Paw Tunnel

This hike is open to all. It will be an easy hike on level ground. We will start at the Paw Paw Tunnel parking lot, walking through the tunnel to the Sorrel Ridge hiker/biker campsite. On our return we may go over the tunnel for some good views of the Potomac River.

**Distance/** 4 miles

**Difficulty:** EASY

**Duration:** 2.5 hours

**Bring:** Water, snacks, footwear appropriate for a hike, and a flashlight for our time in the tunnel.

**Meet:** 10 a.m. Paw Paw Tunnel campground and parking lot, Oldtown Road (MD-51) at the Potomac River

**Leader:** Ken Kendall  
kekendall65@gmail.com  
304-433-9537

**Nearest town:** Paw Paw, WV

**Cancellation policy:** We will cancel if heavy rain or snow is likely.



## Saturday, April 6, 2024

### DAY HIKE: The Appalachian Trail, Chester Gap to Manassas Gap, VA

Our exploration of the Appalachian Trail in Northern Virginia continues with this strenuous but rewarding hike. The hike involves a shuttle, so a reservation is required, and we ask that you let us know if you need to cancel your reservation. This section of the AT includes a 1000-foot ascent on High Knob and a 600-foot climb on a neighboring mountain. Footing is generally good, and we will be rewarded in our efforts with outstanding views from a former pasture atop one of the climbs. The hike is suitable for individuals in good shape. Dress appropriately for a winter walk during which temperatures and conditions could vary. There is no charge for the hike, but contributions are welcome.

**Distance/** 8.2 miles

**Difficulty:** DIFFICULT

**Duration:** 4.5 hours

**Bring:** Plenty of water, lunch, and perhaps some additional snacks. Hiking poles or a walking stick may be helpful.

**Meet:** 9 a.m. AT Trailhead parking off VA 725, 0.1 mile north of its junction with VA 55. From I-66, take exit 13 onto VA 55 at Linden.

**Leader:** Chris Craig  
ccraig@laurellodge.com  
304-433-1260

**Nearest town:** Linden, VA

**Cancellation policy:** We will carry on in light rain or snow but cancel if heavy precipitation or icy conditions are expected.

LEFT: *Thirty-one Sierrans came out to greet the New Year along the C&O Canal towpath. The group started at Snyder's Landing, near Sharpsburg, MD, and walked upstream to Lock #40 and back on a cloudy but mild day.*

PHOTO BY CHRIS CRAIG.

RIGHT: *The bustle of December didn't keep 19 Sierrans from showing up on a sunny day for a hike on the Tuscarora Trail. The hike took the group along Meadow Branch, through bogs, and up leaf-covered hills in Sleepy Creek Wildlife Management Area.*

PHOTO BY CHRIS CRAIG



## Saturday, April 13, 2024

### DAY HIKE: Lakeside Nature Trail, Stonewall Jackson State Park

This gently rolling trail starts at the park lodge and follows along the lake before crossing the park road and meandering up and back along Carrion Bay. The trail offers scenic views of the lake and quiet places in one of the more remote areas of the park. There is a \$5 entry fee into the park.

**Distance/** 3.2 miles

**Difficulty:** EASY

**Duration:** 4 hours

**Bring:** Water, lunch, and footwear appropriate for the conditions.

**Meet:** 10 a.m., Stonewall Jackson Resort lodge, 940 Resort Dr., Roanoke, WV. We will gather in the main parking lot in front of the lodge.

**Leader:** Chrissy Sandy  
chrissysandy@gmail.com  
304-516-1336

**Nearest town:** Weston, WV

**Cancellation policy:** We will carry on in light rain but cancel if downpours are expected.

## DARK WATERS | CONTINUED FROM PAGE 7

We also convinced WVDEP to hold a virtual public hearing on the permit.

The virtual hearing on the draft application will be held on Monday, March 4, from 6-8 p.m. ET. WVDEP will provide information, answer questions, and accept official comments. Pre-registration for the hearing is required. To register, please complete the registration form at <https://forms.gle/9wCZZphmcwh4xtEw7> or call Terry Fletcher at 304-926-0499

ext. 49720 by 5 p.m. the day of the hearing (March 4). Registrants will receive a separate email with the link and call-in number for the virtual hearing once the registration deadline passes. Written comments can also be submitted via email to [DEP.Comments@wv.gov](mailto:DEP.Comments@wv.gov) or regular mail to Director, Division of Water and Management, DEP ATTN: Sharon Mullins, Permitting Section, 601 57th Street SE, Charleston, WV 25304-2345.

**The comment period closes at 5 p.m. ET on Thursday, March 14.** All comments submitted by this date, including those provided at the hearing, will be considered prior to the agency issuing its final determination. If you're reading this, I hope you'll be willing to submit comments and possibly make an appearance at the in-person hearing. 🍃



Taking a break on the Tuscarora Trail, Sleepy Creek Wildlife Management Area in December.

PHOTO BY CHRIS CRAIG

## Saturday, April 20, 2024

### DAY HIKE: Woodmont Natural Resources Management Area

This moderate hike has a total elevation gain of 700 feet. We will be hiking the Wildlife Heritage Trail through the rolling hills and forests of Western Maryland. We should be able to see the forest coming life after winter and some wildlife as well. This hike is open to anyone able to handle a moderate hike on hilly terrain. There is no charge, but donations are welcome.

**Distance/** 4 miles  
**Difficulty:** MODERATE

**Duration:** 2.5 hours

**Bring:** Water, snacks, and footwear appropriate for conditions.

**Meet:** 12 p.m. noon, Woodmont NRMA Wildlife Heritage Trailhead, Woodmont Road, Washington County, MD. From I-68, west of Hancock, MD, take exit 77, turning left onto MD-144 East. In 0.2 mile, turn right onto Woodmont Road. The trailhead will be on your left in 5 miles.

**Leader:** Ken Kendall  
kekendall65@gmail.com  
304-433-9537

**Nearest town:** Hancock, MD

**Cancellation policy:** We will cancel for heavy rain or storms.

## Sunday, May 12, 2024

### DAY HIKE: C&O Canal Towpath, Point of Rocks to Brunswick, MD

The C&O Canal towpath downstream from Harpers Ferry includes good river views, forest, railroad lines, locks, and the beautiful Catocin Aqueduct. It harkens back to the 1830s, when builders of the B&O Railroad and the Canal were racing each other to reach Harpers Ferry. This is an easy, level walk, suitable for those in reasonable condition. Because we will carpool from the meeting place to the hike's start, advance registration is required, and we ask you to let us know if your plans change. There is no charge, but donations are welcome.

**Distance/** 6.8 miles  
**Difficulty:** EASY

**Duration:** 4 hours

**Bring:** Plenty of water and a sack lunch.

**Meet:** 10 a.m. Brunswick MARC Train parking lot, 100 S. Maple Ave., Brunswick, MD. After parking at the large commuter lot, meet at the train station. From there we will carpool to the hike's start at Point of Rocks.

**Leader:** Chris Craig  
ccraig@laurellodge.com  
304-433-1260

**Nearest town:** Brunswick, MD

**Cancellation policy:** We will carry on in light rain but cancel in a storm.

## Saturday, May 25, 2024

### DAY HIKE: C&O Canal towpath, McCoy's Ferry to Fort Frederick State Park

This hike is open to all capable of a multi-hour walk on level ground. We will start at the McCoy's Ferry parking lot on the C&O Canal and walk the towpath to Fort Frederick State Park. Once at the park, we will be able to explore the rebuilt French and Indian War fort. The park will be celebrating its 100th anniversary as a state park and will be featuring living history programs and displays from state and community partners of the park.

**Distance/** 4.5 miles

**Difficulty:** EASY

**Duration:** 3.5

**Bring:** Water, snacks, and footwear appropriate for the conditions.

**Meet:** McCoy's Ferry parking lot, C&O Canal NHP, 10700 McCoy's Ferry Road, Clear Spring, MD. From I-70, take exit 18 toward Clear Spring, MD and turn left onto Cumberland Street/National Pike. In 0.5 mile, turn left onto Boyd Rd. In 2.8 mile, turn right onto MD-56, then left onto McCoy's Ferry Rd. The sign for the parking lot will be in 1 mile.

**Leader:** Ken Kendall  
kekendall65@gmail.com  
304-433-9537

**Nearest town:** Clear Spring, MD

**Cancellation policy:** We will cancel for heavy downpours or thunderstorms.



(L to R) Davis Funk, Hannah Kornacki, Baileigh Rhoads, Corrine Hewes, and Hazel Parker on the North Fork of the Blackwater River, February 3, 2024. No snow left for skiing, but a beautiful day for a hike with the WVU Sierra Student Coalition.

PHOTO BY JIM KOTCON

## FRIEND OF COAL- NOT | [CONTINUED FROM PAGE 7](#)

that coal dust and ash my entire childhood. Not just from my family's coal consumption, but also from the neighbors and the coal industry in this state. It's hard to imagine life any other way. But as an adult, fighting for my children's future, it's important to maintain hope that changes can be made. Our rich history need not be lost, but we can

and need to move to more sustainable ways of producing energy. I would love to see every single mine closed, strip-mine land turned into solar farms, and mountaintop removal cease. I would love to see trade schools and colleges offer training and degrees in solar installation and maintenance so that the people of our state would have cleaner and

less harmful job opportunities. It is possible to move away from burning coal by using alternate renewable energy. The jobs CAN be there. Our future CAN be different! And as proud West Virginians, we are worth it! My words may not be new, but they are worth repeating: I am a Friend of Water, a Friend of Solar. I am not a Friend of Coal. 🌿



Stopping along the Shenandoah River in Shannondale Springs Wildlife Management Area, Jefferson County.

PHOTO BY CHRIS CRAIG

## Saturday, June 15, 2024

### DAY HIKE: Otter Creek Wilderness Loop

2024 marks the 60th anniversary of the Wilderness Act, which provides the strictest protection for some of America's treasured lands. This hike will provide a chance to explore one of West Virginia's nine wilderness areas. We will trace Otter Creek from its headwaters as it cascades down the valley, gathering in pools. We will then climb to a high point on Shavers Mountain before descending to our starting point. This hike is suitable for people in good health with recent experience hiking similar distances. Due to federal regulations, numbers will be restricted on this hike, so reservations are required. There is the possibility that a short, easy out-and-back option might be available as well. Let us know if you are interested in that. There is no charge for this hike, but contributions are welcome. For those wanting to stay in the area the night before, hotels are available in Elkins and camping is available nearby in the national forest.

**Distance/** 9.0 miles  
**Difficulty:** MODERATELY DIFFICULT

**Duration:** 6 hours

**Bring:** Suitable footwear for a 9-mile hike with rocks, stream crossings, and mud. Hiking poles or staffs are recommended. Bring a substantial lunch, plenty of water, and possibly additional snacks.

**Meet:** 9 a.m. Condon Run Trailhead, Monongahela National Forest. From Elkins, drive east on US 33 for 11.5 m., turning left on Stuart Memorial Drive/FR 91. Continue straight at junction onto FR 303 to dead-end at trailhead.

**Leader:** Chris Craig  
 ccraig@laurelodge.com  
 304-433-1260  
 Ken Kendall  
 kekendall65@gmail.com  
 304-433-9537

**Nearest town:** Elkins, WV

**Cancellation policy:** We will carry on in moderate precipitation but cancel if storms or flood conditions are likely.

# SAVE THE DATE! SIERRAFEST 2024!

Celebrate 40 years of the  
 West Virginia Chapter

Friday, October 4 through  
 Sunday, October 6

CEDAR LAKES CONFERENCE  
 CENTER, RIPLEY, WV

Fun and learning  
 for all ages!

More details to come.

QUESTIONS? CONTACT:  
 CANDICE.K.ELLIOTT@GMAIL.COM

The **Mountain State Sierran** is published quarterly by the West Virginia Chapter of Sierra Club and distributed to all paid members — in print (when requested) or electronically. \$1 of each member's annual dues helps offset the cost of producing this newsletter.

EDITOR: **Chris Craig**  
 ccraig@laurelodge.com

COPY EDITOR: **Sara Torres**  
 svtorres@ucla.edu

DISTRIBUTION: **Candice Elliott**  
 candice.k.elliott@gmail.com

GRAPHIC DESIGN: **Jen Rolston**  
 jen@edendesignco.com

PRINTING: **HBP, Inc.**  
 hbp.com

Please contact the Editor for submission guidelines or advertising rates. Contributions to the newsletter may be sent to ccraig@laurelodge.com.

**DEADLINE FOR THE 2024 SUMMER ISSUE:  
 MAY 4, 2024**

Opinions expressed in the *Mountain State Sierran* are those of the contributors and do not necessarily reflect the opinions of the Sierra Club.

## ENVIRONMENTAL JUSTICE:

# When is a NIMBY Not a NIMBY?

**Environmental justice is a hot topic these days. It's often mentioned as a concern in public comments on the siting of big, polluting projects. But what is environmental justice, and how does it differ from the familiar refrain of "Not In My Back Yard" (NIMBY)?**

The EPA has defined environmental justice as "the fair treatment and meaningful involvement of all people regardless of race, color, national origin, or income with respect to the development, implementation, and enforcement of environmental laws, regulations and policies." In other words, the people who will have to live next door to a project have the right to be heard throughout the planning process.

In 2001, the Sierra Club adopted a policy affirming "the right to a clean and healthful environment for all people," "an end to pollution," and "the precautionary principle." The "precautionary principle" states that "when an activity potentially threatens human health or the environment, the proponent of the activity, rather than the public, should bear the burden of proof as to the harmlessness of the activity... lack of full scientific certainty shall not be used as a reason for postponing measures to prevent environmental degradation."

Institute, WV is one of a handful of majority Black communities in West Virginia. As a result of the chemical manufacturing in the area, the town has been subjected to excessive



**BY ALIÉN CURFMAN**

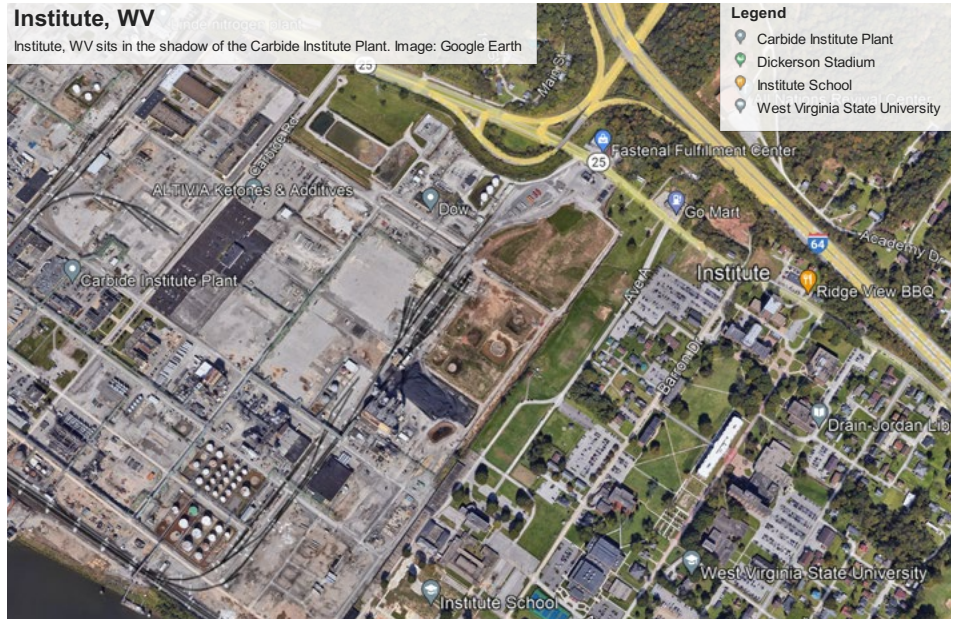

*Institute:* GOOGLE EARTH

levels of ethylene oxide for many years. The Charleston-based watchdog group, People Concerned about Chemical Safety, filed a lawsuit against the EPA in September 2023 for failing to update emissions standards for the adjacent Union Carbide plant. Meanwhile, the residents live with a high cancer risk and many subjective reports of harm. The situation in Institute, WV is representative of larger trends that indicate that communities of color in the U.S. are more likely to be exposed to pollutants. (See, e.g., <http://tinyurl.com/minorities-air-pollution>; <http://tinyurl.com/high-air-pollution-exposure>.)

Low income is another environmental justice criterion. In fact, an entire community, including its leading citizens and wealthiest residents, may be impacted by a legacy of economic exploitation. You may know of a place where natural resources were sold and removed, and little remains for the current residents other

than polluted water, eroded mountainsides, and abandoned infrastructure and towns. It's likely that the average household income in this community is low compared to communities that do not share its devastating history. If the residents' contributions are not sought in the planning process and do not influence decisions, this entire community may indeed be suffering from environmental justice. All residents must have this empowerment, as racial disparities are likely to result in persons of color having the greatest exposure to harmful pollutants.

When communities are advocating for environmental justice, they are sometimes accused of NIMBYism. What's the difference? The NIMBY would say, "The company should locate it more appropriately, in that neighborhood across town." The environmental justice advocate would say, "As this project was conceived, the right place for this project is nowhere on earth. Here's what needs to be done instead." 🗣️

### WANT TO LEARN MORE?

Browse these sources.

<https://www.epa.gov/environmentaljustice>

<http://tinyurl.com/sc-justice>

<http://tinyurl.com/su-toxic-air>

<http://tinyurl.com/mountain-state-air-pollution>

<https://www.wvencyclopedia.org/articles/823>

# West Virginia Chapter Member Survey



Complete the form below and  
clip this mailing label to send.

WEST VIRGINIA SIERRA CLUB  
INTEREST SURVEY  
PO BOX 4142  
MORGANTOWN WV 26504-4142

**We Want to Hear from Our Members and Supporters!** With a newly hired Chapter Director on board and a newly elected Executive Committee raring to go, now is the perfect time for members to share their priorities and interests with Chapter leadership. Complete and mail the following survey or complete it online at [sierraclub.org/west-virginia](http://sierraclub.org/west-virginia).

Members and supporters are our lifeblood. The information you provide helps the volunteers who give their time and energy to advance the interests we all share to focus their strategies and maintain their momentum. Tell us why you became a Sierra Club member, what you hope our organization can accomplish in your area of the state, and how you can help us achieve those goals. Please let us hear from you!

## 1. How did you first become aware of the Sierra Club and its mission?

- Word of mouth from friends or family
- Social media (Please indicate platform: Facebook, IG, TikTok, etc.)  
\_\_\_\_\_
- Personal email from Sierra Club
- Sierra magazine (national)
- Mountain State Sierran (chapter newsletter)
- Went on a Sierra Club outing
- Read a news article
- Other: \_\_\_\_\_

## 2. Why did you decide to join the Sierra Club?

(Please rank any that apply in the order of importance, with 1 being the most important reason.)

- To get the Sierra magazine
- To become more informed about environmental issues
- To get involved with protecting the environment
- To go on hikes and other outings
- To meet like-minded individuals
- To lobby local government officials on environmental issues
- To financially support efforts to protect the environment
- Other: \_\_\_\_\_

## 3. What areas are you most passionate about?

(Please rank in importance.)

- Public lands protection and expansion
- Replacing fossil fuels with clean, renewable energy
- Environmental justice
- Recycling and waste disposal
- Wildlife and fish habitat protection
- Participating in and promoting outdoor recreation activities
- Water and air quality protection
- Other: \_\_\_\_\_

## 4. Which of the following activities would interest you?

(Please check/circle all that apply.)

- Writing (e.g., contribute to WV newsletter, website, or other publications)
- Advocacy (e.g., letter writing, letters to the editor, sending emails, phone calls, attending rallies)
- Lobbying (e.g., outreach to government entities, politicians, or other environmental organizations)
- Interacting with the public (e.g., hosting a table at an event, leading public meetings, outreach to members)
- Leadership (e.g., committee chair, ExCom, outdoor leadership, teaching)
- Supporting Role (e.g., committee member, treasurer, taking notes at meetings)
- Technical Support (e.g., web design and maintenance)
- Fundraising (e.g., researching and writing grants, help with annual appeals to members)
- Outdoor recreation (e.g., attend and/or lead outdoor activities sponsored by the SC)
- Other: \_\_\_\_\_

## 5. At what level are you interested in getting involved with Sierra Club? (Please check any that apply.)

- National level
- State Chapter level
- Local Group level
- Not interested in any level of participation

## 6. Preferred method of Contact:

Email \_\_\_\_\_

Phone \_\_\_\_\_

Preferred times to call: \_\_\_\_\_

Text \_\_\_\_\_

Your Name \_\_\_\_\_



# Sierra Club

West Virginia Chapter

PO Box 4142

Morgantown, WV 26504

[sierraclub.org/west-virginia](http://sierraclub.org/west-virginia)

CHANGE SERVICE REQUESTED

## SPRING 2024

**We Want to Hear From You!**  
 Complete the Survey, p.15 or online at:



This newsletter is printed by HBP Marketing, LLC in Hagerstown, MD on 30% post-consumer, FSC-certified recycled stock, using 0% VOC inks.

# Chapter ExComm Meeting

The next meeting of the WV Chapter of Sierra Club Executive Committee will be held virtually, on ZOOM

**10 am – 4 pm, Saturday, April 6, 2024**

Email John Kotcon at [jkotcon@gmail.com](mailto:jkotcon@gmail.com) for more information or to receive the link.

## MEMBERSHIP COUPON

NAME \_\_\_\_\_  
 ADDRESS \_\_\_\_\_  
 CITY \_\_\_\_\_ STATE \_\_\_\_\_ ZIP \_\_\_\_\_

Check enclosed, made payable to **Sierra Club**. Mail to:  
**Sierra Club • P.O. Box 7059 • Merrifield, VA 22116-7059**

Mastercard  Visa  American Express

CARDHOLDER NAME \_\_\_\_\_

CARD NUMBER \_\_\_\_\_

EXP. DATE \_\_\_\_\_ SIGNATURE \_\_\_\_\_

Contributions, gifts, and dues to the Sierra Club are not tax-deductible; they support our effective citizen-based advocacy and lobbying efforts. Annual membership dues of \$25 or more include \$7.50 for a one-year print subscription to Sierra magazine and \$1.00 for your chapter newsletter.

### MEMBERSHIP CATEGORIES

	INDIVIDUAL	JOINT
<b>INTRODUCTORY</b>	<input type="checkbox"/> \$15	
<b>REGULAR</b>	<input type="checkbox"/> \$39	<input type="checkbox"/> \$49
<b>SUPPORTING</b>	<input type="checkbox"/> \$75	<input type="checkbox"/> \$100
<b>CONTRIBUTING</b>	<input type="checkbox"/> \$150	<input type="checkbox"/> \$175
<b>LIFE</b>	<input type="checkbox"/> \$1,000	<input type="checkbox"/> \$1,250



F94Q **W 5700** -1

EXPLORE, ENJOY, AND PROTECT THE PLANET

## Public Officials

### U.S. SENATE

Washington, DC 20510

#### The Hon. Joe Manchin (D)

(202) 224-3954  
[manchin.senate.gov](http://manchin.senate.gov)

#### The Hon. Shelley Moore Capito (R)

(202) 224-6472  
[capito.senate.gov](http://capito.senate.gov)

### U.S. HOUSE OF REPRESENTATIVES

Washington, DC 20515

#### The Hon. Carol Miller (R, 1st)

(202) 225-3452  
[miller.house.gov](http://miller.house.gov)

#### The Hon. Alex Mooney (R, 2nd)

(202) 225-2711  
[mooney.house.gov](http://mooney.house.gov)

### WHITE HOUSE

Washington, DC 20515

#### Comments Line

(202) 456-1111

#### Fax

(202) 456-2461

#### Capitol Switchboard

(202) 224-3121

### WV STATE LEGISLATORS

Member, WV Senate or House of Delegates  
Bldg 1, State Capitol Complex  
Charleston, WV 25305

**WVlegislature.gov** has contact information for all state legislators.

(877) 565-3447 or (304) 347-4836

### GOVERNOR JIM JUSTICE

State Capitol, Charleston, WV 25305  
(888) 438-2731 • [governor.wv.gov](http://governor.wv.gov)